

BXN

type

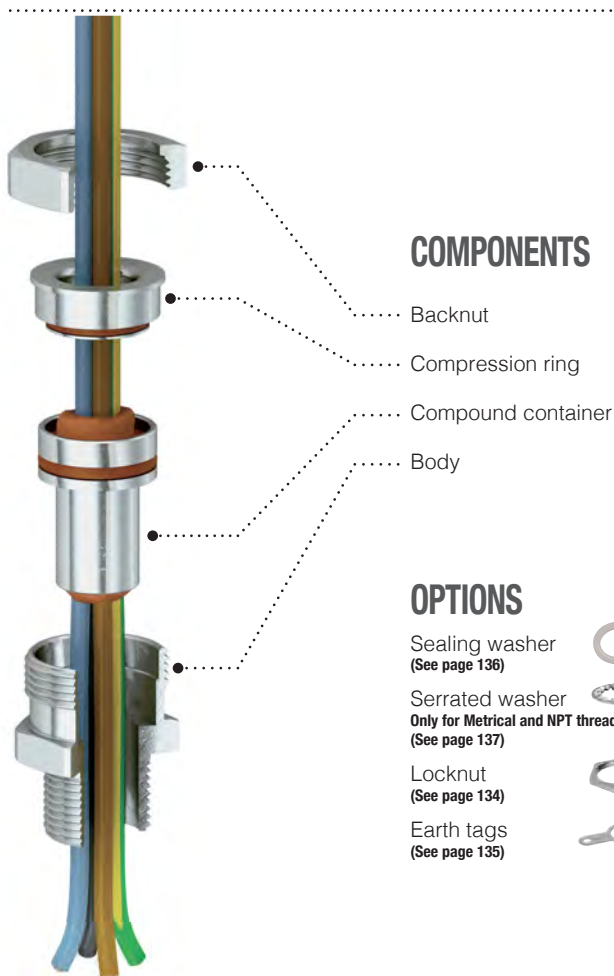

FLAMEPROOF EX D • INCREASED SAFETY EX E • FOR INDOOR & OUTDOOR APPLICATIONS
FOR UNARMoured CABLES



COMPONENTS

- Backnut
- Compression ring
- Compound container
- Body

OPTIONS

- Sealing washer (See page 136)
- Serrated washer (Only for Metrical and NPT threads. See page 137)
- Locknut (See page 134)
- Earth tags (See page 135)

1 Cable glands BXN type (code: BXN)

The cable glands of the BXN series have been designed for sealing one or more cores. It has a body which houses the container intended to contain the epoxy resin for sealing the cores. Above the container is positioned a spacer whose function together with the backnut that is going to be screwed onto the body of the cable gland is to lock the container in position.

Application fields Surface - Group II • Mines - Group I

Approvals / Certifications

ATEX certificate: CESI 14ATEX069X
IEC Ex certificate: IECEx CES 15.0001X
UKCA certificate: CML 21UKEX1594X
EAC certificate: НАСТХОЛ RU C-IT.АЯ45.В.00909
CCC Ex NEPSI certificate: Nr. 2021322313003704

Protection type

Ex db IIC • Ex eb II (gas) • Ex tb IIIC (dusts) • Ex db I • Ex eb I (mines)

EPL (Equipment protection level)

Zone 1-2: Mb mines • Gb, Gc gas
Zone 21-22: Db Dc combustible dusts

Execution

Ex db IIC • Ex eb II • Ex tb IIIC • Ex db I • Ex eb I Db according to
ATEX: EN IEC 60079-0:2018 • EN 60079-1:2014 • EN IEC 60079-7:2015/A1:2018 • EN 60079-31:2014 • EN 60529:1991
IEC Ex: IEC 60079-0:2017 • IEC 60079-1:2014 • IEC 60079-7:2015/A1:2017 • IEC 60079-31:2013
IEC 60529:1989+A1:1999+A2:2013

Ambient temperatures range:

-60°C ÷ +110°C

Service temperatures range:

-60°C ÷ +130°C

Cable type

Unarmoured

6 Available materials

Brass (code: **OT**) • Nickel-plated brass (code: **ON**)
AISI316L Stainless steel (code: **S6**) • Aluminium (code: **AL**)

Available threads

ISO 262 Metrical • ISO 228 • DIN 40430 Pg
ANSI B1.20.1 NPT • EN 10226 Gk (only for ATEX)

Degree of protection

The cable glands degree of protection is **IP66** or **IP66/68**, 30-meters depth for 7 days according to the IEC EN 60529 standard; the degree of protection IP 68 is obtained by using flat sealing rings on cable glands with cylindrical threads. Without gaskets, the degree of protection is IP 66. If the cable glands with cylindrical or tapered threads are screwed on the threaded hole of an apparatus, in order to guarantee an IP66 or IP66/68 degree of protection, threaded parts must be sealed with Loctite or similar. In order to maintain the IPX8 degree of protection, the cable entry shall be fitted on enclosure witch satisfies an immersion test under 30 meters of water during 7 days. Metric cable glands are made in accordance to EN 62444 Standard.

COMPOUND
Application
Mixing time
Full cure time
Installation

SOLID
By hand
30 min
4 hours
Any Orientation

DESIGNED FOR SEALING ONE OR MORE CORES

EXAMPLE CODE

See page 43

1 2 4 6

BXN	25.	N25.	ON
Type	Size	Ø D Thread code	Material code

See tab.
page 43

OT	Brass
ON	Nickel-plated brass
S6	AISI316L Stainless steel
AL	Aluminium

TECHNICAL DRAWING

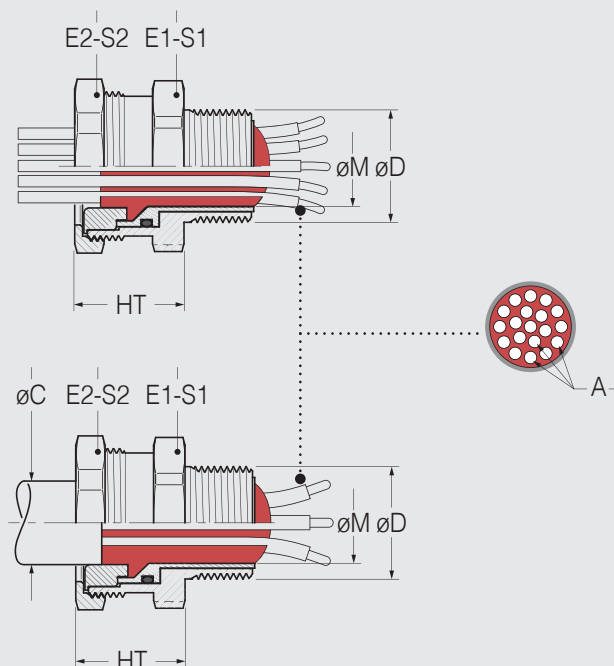

SIZE	Ø D - THREADS					DIMENSIONS									
	Cylindrical			Tapered		Weight	ØC Max Ø ext. conductor	ØM Max over multicores	A Max no conductors	HT	E1	S1	E2	S2	
	ISO 262	ISO 228	DIN 40430	NPT	EN 10226										
16	M16x1,5 M20x1,5	3/8" 1/2"	Pg11 Pg13,5	3/8" 1/2"	3/8" 1/2"	90	8	9,4	10	24	25	27	26	29	
20	M20x1,5	1/2"	Pg13,5 Pg16	1/2"	1/2"	113	10,5	12,4	15	24,5	28	30,8	30	33	
25	M25x1,5	3/4"	Pg21	3/4"	3/4"	156	14	17,6	30	25,5	34	38	35	38,7	
32	M32x1,5	1"	Pg29	1"	1"	258	18,5	22,8	50	26	43	47	45	50	
40	M40x1,5	1" 1/4	Pg36	1" 1/4	1" 1/4	357	24,5	28	75	27	52	57	55	60	
50	M50x1,5	1" 1/2	Pg36	1" 1/2	1" 1/2	394	29,5	34,5	80	28	55	61	57	63	

• Standard Threads in bold • Dimensions are in millimeters