

# RALD

type



FLAMEPROOF EX D • INCREASED SAFETY EX E • FOR INDOOR & OUTDOOR APPLICATIONS  
FOR ARMoured CABLES • INNER LEAD SHEATED



## 1 Cable glands RALD type (code: RALD)

The sealing ring blocks the cable on the under armour diameter. The addition of the sealing ring on the outer sheath guarantees a complete protection of the cable armour. The lead ring, grounds the lead sheath of the cable. Cable glands EMC tested by triaxial method, according to IEC 62153-4-3, IEC 62153-4-4 standards. Metric cable glands are made according to EN 62444 standard. Maintenance and installation operations and product selection must be done in accordance with IEC EN 60079-14 and 17 standards.

**Application fields** Surface - Group II • Mines - Group I

### Approvals / Certifications

ATEX certificate: INERIS 06 ATEX 0014X  
Type examination certificate: INERIS 17 ATEX 3009X (Ex nR IIC Gc)  
IEC Ex certificate: IEC Ex INE 10.0010X  
UKCA certificate: CML 21UKEX1590X  
UKCA certificate (Cat 3): CML 21UKEX1591X  
EAC certificate: НАСТХОЛ RU C-IT.АЯ45.В.00909  
CCC Ex NEPSI Certificate: Nr. 2021322313003706

### Protection type

Ex db IIC • Ex eb II (gas) • Ex tb IIIC (dusts) • Ex db I • Ex eb I (mines)

### EPL (Equipment protection level)

**Zone 1-2:** Mb mines • Gb, Gc gas  
**Zone 21-22:** Db Dc combustible dusts

### Execution

Ex db IIC • Ex eb II • Ex tb IIIC • Ex db I • Ex eb I Db according to  
**ATEX:** EN IEC 60079-0:2018 • EN 60079-1:2014 • EN IEC 60079-7:2015/A1:2018 • EN 60079-15:2010 • EN 60079-31:2014 • EN 60529:1991  
**IEC Ex:** IEC 60079-0:2017 • IEC 60079-1:2014 • IEC 60079-7:2015/A1:2017 • IEC 60079-15:2017 • IEC 60079-31:2013 • IEC 60529:1989+A1:1999+A2:2013

## 5 Ambient temperatures in services: sealing washers materials

EPDM seals -40°C ÷ +100°C (code: **EP**)  
Silicone seals -65°C ÷ +220°C (code: **SI**)

### Cable type

Armoured: Single armoured cable SWA, Aluminium wire armoured cable AWA, Aluminium strip armoured ASA. Single wire braided cable SWB, Steel tape armoured cable STA, Pliable wire armoured cable PWA. Screened flexible wire braided cable CY-SY  
**Reduced cone available for SWA armoured cables.**

## 6 Available materials

Brass (code: **OT**) • Nickel-plated brass (code: **ON**)  
AISI316L Stainless steel (code: **S6**) • Aluminium (code: **AL**)  
AVP Steel (code: **AVP**)

### Available threads

ISO 262 Metrical • ISO 228 • DIN 40430 Pg  
ANSI B1.20.1 NPT • EN 10226 Gk (only for ATEX)

### Degree of protection

The cable glands degree of protection is **IP66** or **IP66/68**, 30-meters depth for 7 days according to the IEC EN 60529 standard; the degree of protection IP 68 is obtained by using flat sealing rings on cable glands with cylindrical threads. Without gaskets, the degree of protection is IP 66. If the cable glands with cylindrical or tapered threads are screwed on the threaded hole of an apparatus, in order to guarantee an IP66 or IP66/68 degree of protection, threaded parts must be sealed with Loctite or similar. In order to maintain the IPX8 degree of protection, the cable entry shall be fitted on enclosure with satisfies an immersion test under 30 meters of water during 7 days. Metric cable glands are made in accordance to EN 62444 Standard.

## 0 Kit version (code: KIT)

Includes cable glands and the requested complete series of the rubber seals accompanying the size.

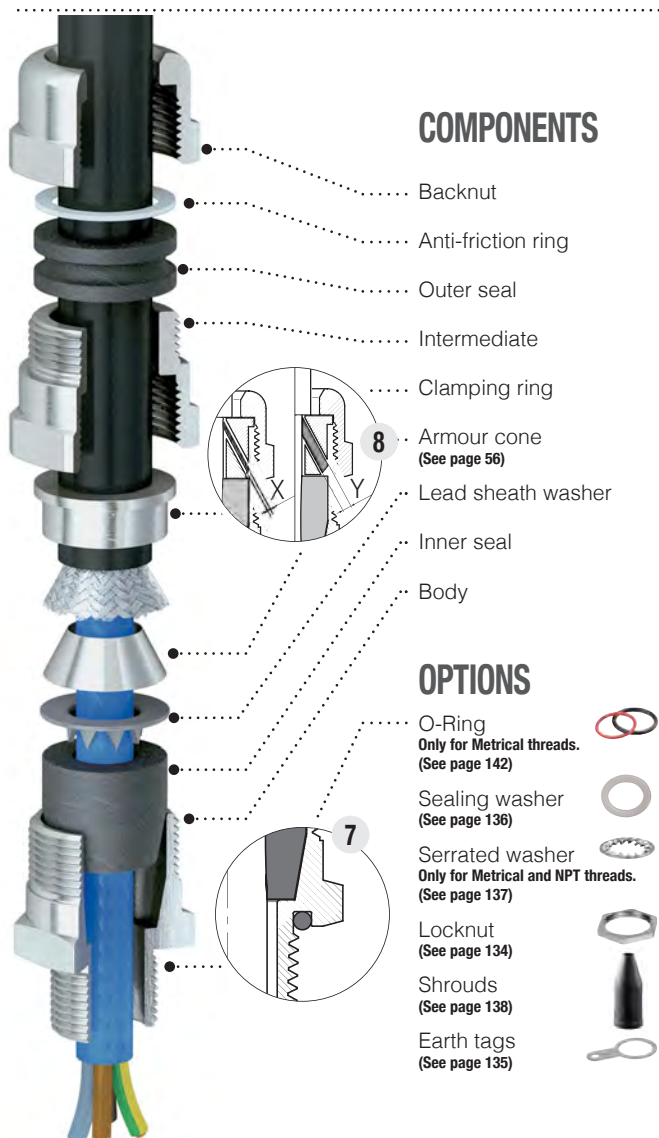

## COMPONENTS

- Backnut
- Anti-friction ring
- Outer seal
- Intermediate
- Clamping ring
- 8 Armour cone (See page 56)
- Lead sheath washer

- Inner seal
- Body

## OPTIONS

- 7 O-Ring  
Only for Metrical threads.  
(See page 142)
- Sealing washer  
(See page 136)
- Serrated washer  
Only for Metrical and NPT threads.  
(See page 137)
- Locknut  
(See page 134)
- Shrouds  
(See page 138)
- Earth tags  
(See page 135)



## EXAMPLE CODE

See page 56

## TECHNICAL DRAWING

0 1 2 3 3E 4 5 6 7 8

<b>KIT.</b>	<b>RALD</b>	<b>25.</b>	<b>13.</b>	<b>24.</b>	<b>N25.</b>	<b>EP.</b>	<b>ON.</b>	<b>OR.</b>	<b>BS</b>
Optional code	Type	Size	∅ C Max	∅ Ce Max	∅ D Thread code	Seals material code	Material code	Optional code	Optional code
Kit series			Inner seal (10,5 ÷ 13)	Outer seal (19 ÷ 24)	See tab. page 57	EP-SI	OT-ON-S6 AL-AVP	O-Ring	Reduced cone

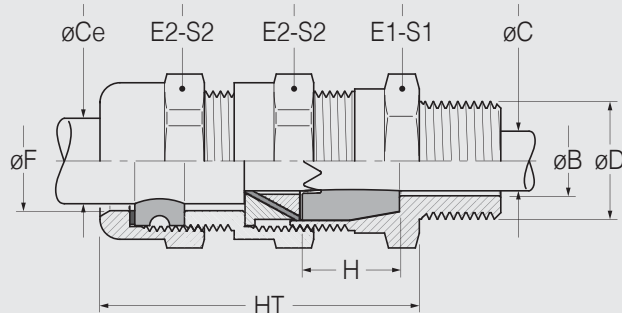

SIZE	∅ C Min - Max Inner seal	∅ Ce Min - Max Outer seal	ARMOUR RANGE		∅ D - THREADS					DIMENSIONS							
			Standard cone X*	Reduced cone Y**	Cylindrical			Tapered		Weight	F	HT	H	E1	S1	E2	S2
					ISO 262	ISO 228	DIN 40430	NPT	EN 10226								
16 (EP)	4 ÷ 7 7 ÷ 10	5 ÷ 10 10 ÷ 15	0 ÷ 0,5	0,5 ÷ 0,75	M12x1,5	1 / 4"	Pg7	1 / 4"	1 / 4"	126	16	58	20	24	26	24	26
16 (SI)	4 ÷ 6 6 ÷ 8 8 ÷ 10				M16x1,5 M20x1,5	3 / 8" 1 / 2"	Pg9 Pg11 Pg13,5	3 / 8" 1 / 2"	3 / 8" 1 / 2"								
20	5,5 ÷ 8 8 ÷ 10,5 10,5 ÷ 13	10 ÷ 15 14 ÷ 19	0 ÷ 0,5	0,5 ÷ 1,25	M16x1,5 M20x1,5 M25x1,5	1 / 2" 3 / 4"	Pg11 Pg13,5 Pg16	1 / 2" 3 / 4"	1 / 2" 3 / 4"	228	20	64	20	30	33	32	35
25	8 ÷ 10,5 10,5 ÷ 13 13 ÷ 15,5 15,5 ÷ 18	15 ÷ 20 19 ÷ 24	0 ÷ 0,5	0,5 ÷ 1,25	M20x1,5 M25x1,5	3 / 4" 1"	Pg16 Pg21	3 / 4" 1"	3 / 4" 1"	264	25	64	20	35	38	36	39
32	13 ÷ 15,5 15,5 ÷ 18 18 ÷ 21 21 ÷ 24	20 ÷ 26 25 ÷ 31	0 ÷ 1	1 ÷ 1,6	M25x1,5 M32x1,5	1"	Pg21 Pg29	1"	1"	484	32	83	25	42	47	45	49
40	21 ÷ 24 24 ÷ 27 27 ÷ 30 24 ÷ 27	26 ÷ 32 31 ÷ 37	0 ÷ 1	1 ÷ 1,6	M40x1,5	1" 1/4	Pg29	1" 1/4	1" 1/4	576	38	83	25	48	53	50	55
50	24 ÷ 27 27 ÷ 30 30 ÷ 33 33 ÷ 36	31 ÷ 37 36 ÷ 43	0 ÷ 1	1 ÷ 2	M40x1,5 M50x1,5	1" 1/2	Pg36	1" 1/2	1" 1/2	730	44	83	25	55	60	57	62
63	36 ÷ 39 39 ÷ 42 42 ÷ 45	42 ÷ 48 47 ÷ 53	0 ÷ 1	1 ÷ 2	M50x1,5 M63 x 1,5	2"	Pg42 Pg48	2"	2"	961	54	83	25	68	74	67	73
75	45 ÷ 48 48 ÷ 51 51 ÷ 54	52 ÷ 58 58 ÷ 64	0 ÷ 1	1 ÷ 2	M63x1,5 M75x1,5	2" 1/2	Pg48	2" 1/2	2" 1/2	1392	65	83	25	80	86	80	88
90a	54 ÷ 58 58 ÷ 62	64 ÷ 72	0 ÷ 2	2 ÷ 2,5	M75x1,5	3"	/	3"	3"	3026	74	115	30	100	107	100	107
90b	60 ÷ 64 64 ÷ 68	70 ÷ 78			2432					80							

• Standard Threads in bold • Dimensions are in millimeters • Weight in grams (gr) of brass version

• Inside the size, the external rubber seals may be matched with any interior rubber seals, compatible with the cable size. (See on page 57)

\* Standard cone X: Suitable for all approved armour cables except SWA cables \*\* 8 Reduced cone Y: Suitable for SWA cables (code: BS)