

RAM type



FLAMEPROOF EX D • INCREASED SAFETY EX E • FOR INDOOR & OUTDOOR APPLICATIONS
FOR ARMoured CABLES • UNDER ARMOUR SHEATH SEALING



1 Cable glands RAM type (code: RAM)

The sealing ring blocks the cable on the diameter under armour. The cone rings grips and grounds the cable armour. The addition of male thread on the backnut allows the cable gland to be coupled to a conduit fitting. Cable glands EMC tested by triaxial method, according to IEC 62153-4-3, IEC 62153-4-4 standards. Metric cable glands are made according to EN 62444 standards. Maintenance and installation operations and product selection must be done in accordance with IEC EN 60079-14 and 17 standards.

Application fields Surface - Group II • Mines - Group I

Approvals / Certifications

ATEX certificate: INERIS 06 ATEX 0014X
 Type examination certificate: INERIS 17 ATEX 3009X (Ex nR IIC Gc)
 IEC Ex certificate: IEC Ex INE 10.0010X
 UKCA certificate: CML 21UKEX1590X;
 UKCA certificate (Cat 3): CML 21UKEX1591X
 EAC certificate: НАСТХОЛ RU C-IT.АЯ45.В.00909
 CCC Ex NEPSI Certificate: Nr. 2021322313003706

Protection type

Ex db IIC • Ex eb II (gas) • Ex tb IIIC (dusts) • Ex db I • Ex eb I (mines)

EPL (Equipment protection level)

Zone 1-2: Mb mines • Gb, Gc gas

Zone 21-22: Db Dc combustible dusts

Execution

Ex db IIC • Ex eb II • Ex tb IIIC • Ex db I • Ex eb I Db according to

ATEX: EN IEC 60079-0:2018 • EN 60079-1:2014 • EN IEC 60079-7:2015/A1:2018 • EN 60079-15:2010 • EN 60079-31:2014 • EN 60529:1991

IEC Ex: IEC 60079-0:2017 • IEC 60079-1:2014 • IEC 60079-7:2015/A1:2017 • IEC 60079-15:2017 • IEC 60079-31:2013 • IEC 60529:1989+A1:1999+A2:2013

5 Ambient temperatures in services: sealing washers materials

EPDM seals -40°C ÷ +100°C (code: **EP**)

Silicone seals -65°C ÷ +220°C (code: **SI**)

Cable type

Armoured: Single armoured cable SWA, Aluminium wire armoured cable AWA, Aluminium strip armoured ASA. Single wire braided cable SWB, Steel tape armoured cable STA, Pliable wire armoured cable PWA. Screened flexible wire braided cable CY-SY

Reduced cone available for SWA armoured cables.

6 Available materials

Brass (code: **OT**) • Nickel-plated brass (code: **ON**)

AISI316L Stainless steel (code: **S6**) • Aluminium (code: **AL**)

AVP Steel (code: **AVP**)

Available threads

ISO 262 Metrical • ISO 228 • DIN 40430 Pg

ANSI B1.20.1 NPT • EN 10226 Gk (only for ATEX)

Degree of protection

The cable glands degree of protection is **IP66** or **IP66/68**, 30-meters depth for 7 days according to the IEC EN 60529 standard; the degree of protection IP 68 is obtained by using flat sealing rings on cable glands with cylindrical threads. Without gaskets, the degree of protection is IP 66. If the cable glands with cylindrical or tapered threads are screwed on the threaded hole of an apparatus, in order to guarantee an IP66 or IP66/68 degree of protection, threaded parts must be sealed with Loctite or similar. In order to maintain the IPX8 degree of protection, the cable entry shall be fitted on enclosure which satisfies an immersion test under 30 meters of water during 7 days. Metric cable glands are made in accordance to EN 62444 Standard.

0 Kit version (code: KIT)

Includes cable glands and the requested complete series of the rubber seals accompanying the size.

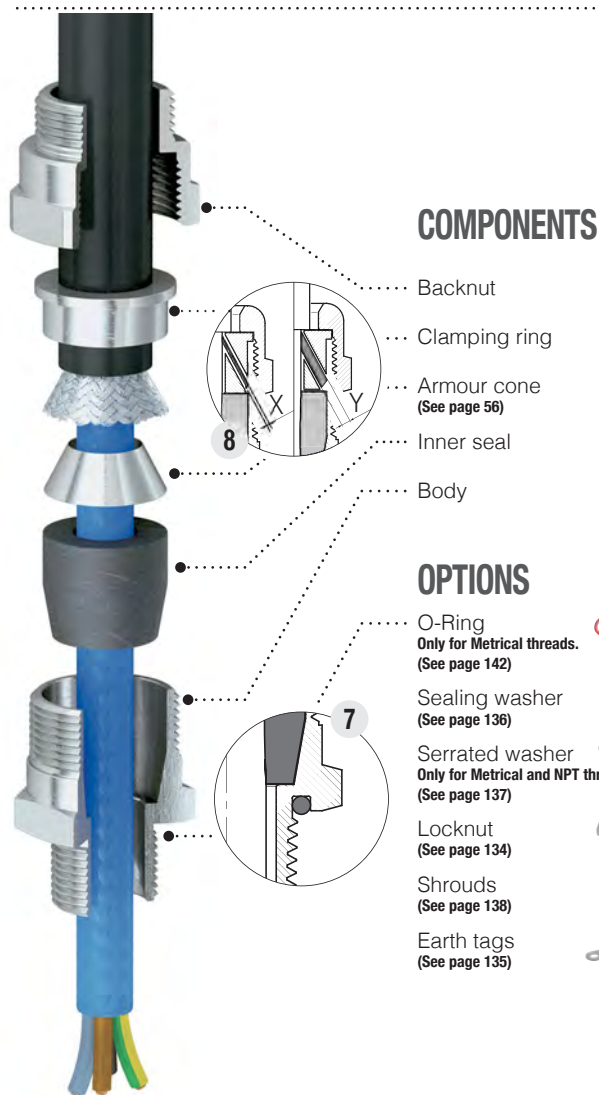

COMPONENTS

- Backnut
- Clamping ring
- Armour cone (See page 56)
- Inner seal
- Body

OPTIONS

- O-Ring Only for Metrical threads. (See page 142)
- Sealing washer (See page 136)
- Serrated washer Only for Metrical and NPT threads. (See page 137)
- Locknut (See page 134)
- Shrouds (See page 138)
- Earth tags (See page 135)



EXAMPLE CODE

See page 56

TECHNICAL DRAWING

0 1 2 3 4 4E 5 6 7 8

KIT.	RAM	25.	13.	N25.	N25.	EP.	ON.	OR.	BS
Optional code	Type	Size	Ø C Max	Ø D Thread code	Ø De Thread code	Seals material code	Material code	Optional code	Optional code
Kit series			Inner seal (10,5 ÷ 13)	See tab. page 57	See tab. page 57	EP-SI	OT-ON-S6 AL-AVP	O-Ring	Reduced cone

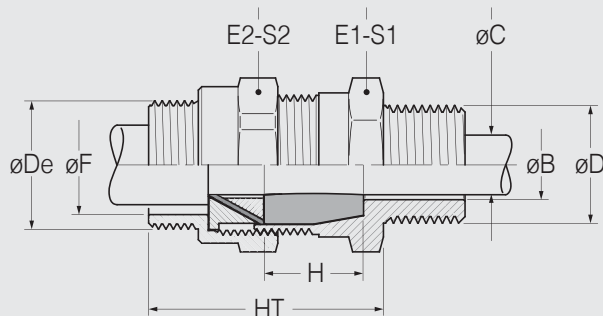

SIZE	Ø C Min - Max Inner seal	ARMOUR RANGE		Ø D - THREADS					Ø De - THREADS					DIMENSIONS											
		Standard cone X*	Reduced cone Y**	Cylindrical			Tapered		Cylindrical			Tapered		Weight	F	HT	H	E1	S1	E2	S2				
				ISO 262	ISO 228	DIN 40430	NPT	EN 10226	ISO 262	ISO 228	DIN 40430	NPT	EN 10226												
16 (EP)	4 ÷ 7 7 ÷ 10																								
16 (SI)	4 ÷ 6 6 ÷ 8 8 ÷ 10	0 ÷ 0,5	0,5 ÷ 0,75	M12x1,5 M16x1,5 M20x1,5	1 / 4" 3 / 8" 1 / 2"	Pg7 Pg9 Pg11 Pg13,5	1 / 4" 3 / 8" 1 / 2"	1 / 4" 3 / 8" 1 / 2"	M16x1,5	3 / 8"	/	3 / 8"	/	101	11	51	20	24	26	24	26				
20	5,5 ÷ 8 8 ÷ 10,5 10,5 ÷ 13	0 ÷ 0,5	0,5 ÷ 1,25	M16x1,5 M20x1,5 M25x1,5	1 / 2" 3 / 4"	Pg11 Pg13,5 Pg16	1 / 2" 3 / 4"	1 / 2" 3 / 4"	M20x1,5	1 / 2"	/	1 / 2"	/	174	15	52	20	30	33	32	35				
25	8 ÷ 10,5 10,5 ÷ 13 13 ÷ 15,5 15,5 ÷ 18	0 ÷ 0,5	0,5 ÷ 1,25	M20x1,5 M25x1,5	3 / 4" 1"	Pg16 Pg21	3 / 4" 1"	3 / 4" 1"	M25x1,5	3 / 4"	/	3 / 4"	/	206	19	52	20	35	38	36	39				
32	13 ÷ 15,5 15,5 ÷ 18 18 ÷ 21 21 ÷ 24	0 ÷ 1	1 ÷ 1,6	M25x1,5 M32x1,5	1"	Pg21 Pg29	1"	1"	M32x1,5	1"	/	1"	/	356	25	62	25	42	47	45	49				
40	21 ÷ 24 24 ÷ 27 27 ÷ 30	0 ÷ 1	1 ÷ 1,6	M40x1,5	1" 1/4	Pg29	1" 1/4	1" 1/4	M40x1,5	1" 1/4	/	1" 1/4	/	431	31	62	25	48	53	50	55				
50	24 ÷ 27 27 ÷ 30 30 ÷ 33 33 ÷ 36	0 ÷ 1	1 ÷ 2	M40x1,5 M50x1,5	1" 1/2	Pg36	1" 1/2	1" 1/2	M50x1,5	1" 1/2	/	1" 1/2	/	568	42	62	25	55	60	57	62				
63	36 ÷ 39 39 ÷ 42 42 ÷ 45	0 ÷ 1	1 ÷ 2	M50x1,5 M63x1,5	2"	Pg42 Pg48	2"	2"	M63 x 1,5	2"	/	2"	/	784	47	63	25	68	74	67	73				
75	45 ÷ 48 48 ÷ 51 51 ÷ 54	0 ÷ 1	1 ÷ 2	M63x1,5 M75x1,5	2" 1/2	Pg48	2" 1/2	2" 1/2	M75x1,5	2" 1/2	/	2" 1/2	/	1124	62	62	25	80	86	80	88				
90a	54 ÷ 58 58 ÷ 62	0 ÷ 2	2 ÷ 2,5	M75x1,5 M90x2	3"	/	3"	3"	M90x2	3"	/	3"	/	2235	72	77	30	100	107	100	107				
90b	60 ÷ 64 64 ÷ 68													1852											

• Standard Threads in bold • Dimensions are in millimeters • Weight in grams (gr) of brass version

* Standard cone X: Suitable for all approved armour cables except SWA cables ** 8 Reduced cone Y: Suitable for SWA cables (code: BS)